

AC/DC power supply unit

KAN-D product line

KAN-D75, 75 W

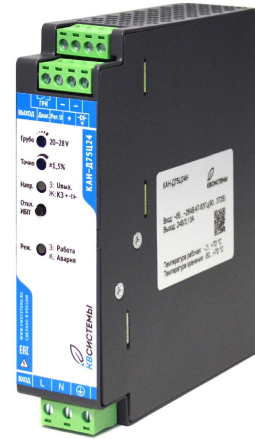

Global Data

Power	75 W
Output current	up to 6,3 A
Input voltage	=220 (85...264) V
Output voltage	=12 V; =24 V; = 48 V
Efficiency	≥ 88%
Ambient operating temperature	-25...+70 °C; -50...+70 °C
Dry contact.....	Based on high-current relay
EMC standart	ENC55022 (CISPR22)
Replacement/Installation	Toolless
Installation.....	DIN rail
Dimentions	33×134×131 mm
Warently	2 years

Advantages

- ◀ Parallel and series connection without additional components
- ◀ Compliance with SIL2 safety level
- ◀ Built-in UPS function

Ordering information

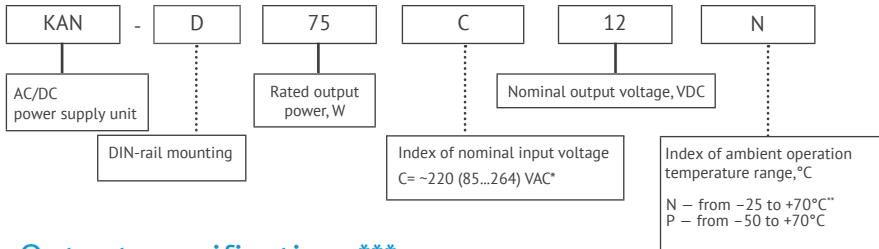

Output specifications***

Parameter		Value			
Model		KAN-D75C12X	KAN-D75C24X	KAN-D75C48X	
Output power, W		75 W 100 W at $t_{nom} < 50^\circ\text{C}$ and $U_{in} = 176...264\text{ V}$			
Nominal output voltage, VDC		12	24	48	
Output voltage adjustment range, V	by built-in potentiometr	precise	$\pm 1.5\%$	$\pm 1.5\%$	
		rough	10...14	20...28	
	by Adj.U	$\pm 5\%$			
Efficiency, %		min. 88			
Rated output current, A		6,25	3,125	1.6	
Ripple and noise (peak-to-peak)		<2% $U_{out, nom.}$			
Line and load regulation		no more 2%			
Start-up time***, sec		1			
Dissipated power, no load***, max, W		5			
Dissipated power, nominal load ² , max, W		7			
Serviceability output signal	Dry contact	Maximum switchable voltage and current	250 VAC/ 30 VDC/ 5 A		
		Relay current consumption, mA	35	17	10
		Relay cut-off voltage, V	8...10	18...20	36...40
	"Diag" output		open collector 100 mA, 45 V max		
Parallel operation****		yes, redundancy and power boost			
Serial connection		+			
Maximum load capacity, μF		200000	47000	57000	

Input specifications***

Parameter	Value
Input voltage range, VAC	$\sim 85...264 (= 90...372)$
Mains frequency range, Hz	47-63 AC
	0 DC
Consumed current, A	0.69 (~120 V) 0.33 (~220 V)
Inrush current	20 A
Pre-fuse	3.5 (inert type, internal)

* For KAN-D75CXXX

**The module can be started at -40 degrees.

***All specifications are valid for normal climatic conditions, $U_{in, nom.}$, $I_{out, nom.}$, unless otherwise noted.

****For precise output voltage adjustment in parallel operation mode the «precise» trim resistor is used.

Protections

Type of protection	
Short-circuit protection*	yes, auto recovery
Overcurrent protection**	$P_{max} < 1.8 P_{nom}$
Overvoltage protection**, V	$< 125\% U_{out nom}$
Protection against impulse overvoltages	varistor

Basic specifications

Parameter		Value
Type of connection		plug-in screw terminals
Derating		-2% / °C after +60°C
Degree of protection		IP20
EMC requirements		EN55022 (CISPR22), Class B
Ambient temperature, operation , °C	N	-25...+70°C
	P	-50...+70°C*
Ambient temperature, storage, °C		-50...+70°C
Permissible humidity(operation)		85% at t° ambient +40°C (95% at t°C ambient +25°C)
Isolation voltage, V	in /case	~3000 VAC
	in /out	~3000 VAC
	out /case	~1500 VAC
Isolation resistance @ 500 VDC		≥ 20 MOhm min
Cooling		convectioanal
MTBF		1400000 Hrs
Case material		metal
Dimensions, mm		33x131x134
Weight, kg		no more than 0.6
Mounting position		Vertical, for horizontal DIN-rail NS35
Mounting instructions		Indentation between modules should be 5 mm horizontally for non-active modules and 15 mm for active modules. Vertically, there should be a minimum of 50 mm.
Warranty		2 years

* Starting at XX from -50°C, operating temperature from -40°C.

Block diagram

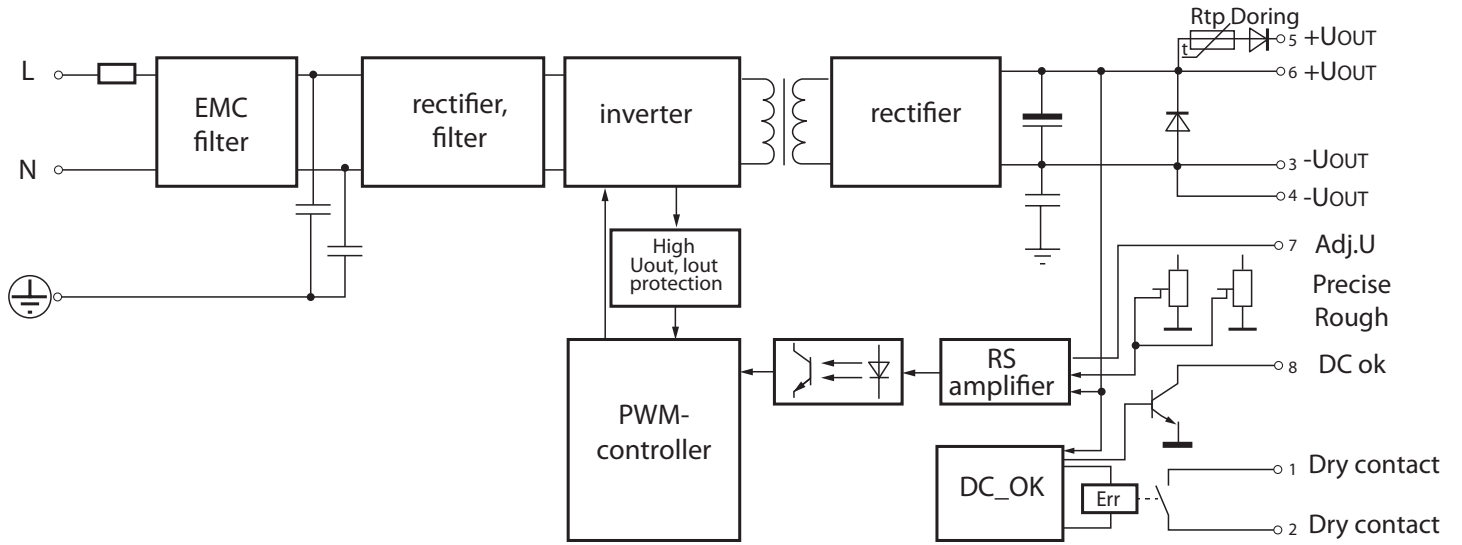

Connection diagram Typical connection

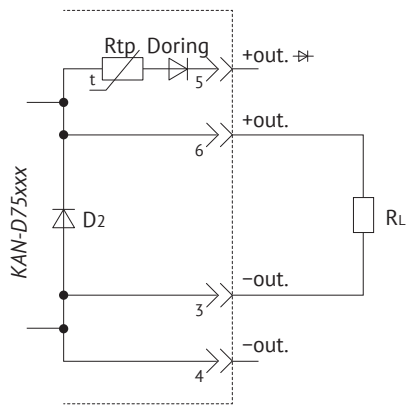

Typical operation: Connect the load to the inverter as shown in the figure above. Set the output voltage at the "+Out" output using the "coarse" and "fine" controls. (Do not use the "+Out Oring" output for voltage setting).

Series connection

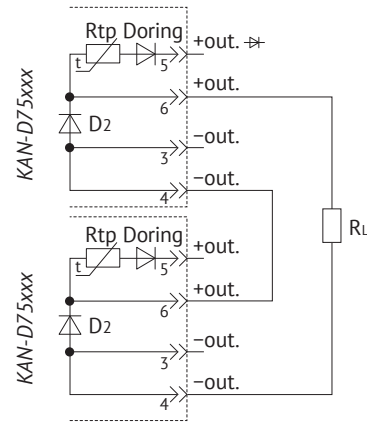

Series connection: connect the load to the inverters as shown in the figure above. Set the same voltage between the "+Out" and "-Out" terminals of each inverter using the "coarse" and "fine" controls. (Do not use the "+Out Oring" output for voltage setting).

Parallel connection

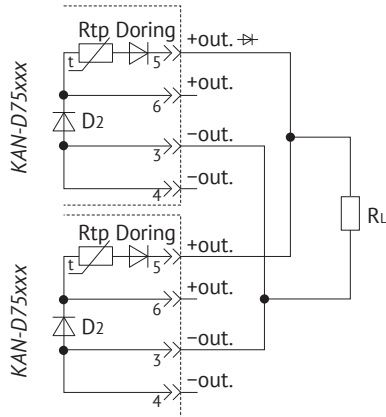

Parallel connection: Connect the load to the inverters as shown above. Set the same voltage between the "+Out" and "-Out" terminals of each inverter using the "coarse" and "fine" regulator with a spread of no more than 0.25%. When setting, take into account the voltage drop across the Doring diode of 0.35; 0.45; 0.6 V for 12, 24 and 48 V versions respectively.

Check the voltage between the terminals "+Out Oring" and "-Out". Repeat the adjustment if necessary.

UPS mode

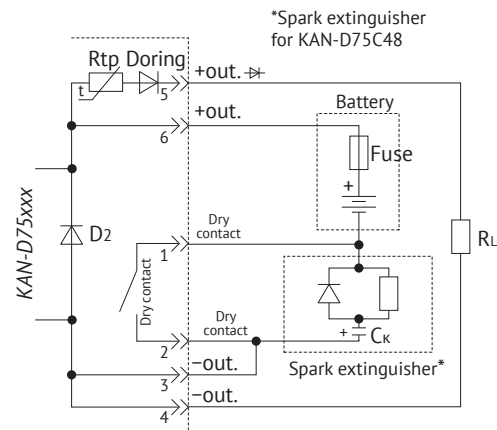

To operate KAN-D75 in UPS or buffer mode, it is necessary:

1. Supply input voltage to the converter. Set on "+Out" by means of regulators "roughly" and "exactly" voltage necessary for battery operation in buffer (Stand by) mode (see battery documentation).
2. Connect the load and the battery according to the figure above. The presence of a fuse is mandatory. In the 12 V and 48 V versions, a fuse with a maximum rating of 12 A is used. For 48 V version it is recommended to use a self-resetting fuse with operating voltage of 60 V and operating current not more than 4 A
3. Forced disconnection of the UPS output voltage in case of mains voltage failure is performed by pressing the "Disconnect" button. "UPS" button on the front panel

* Spark arrester circuit is required for 48V version (KAN-D75C48) and is used to prevent arcing on relay contacts. Schematic diagram and ratings of the spark arrester circuit are given in Fig.5.

Connection diagram

Load connection scheme in buffer mode, bypassing Doring

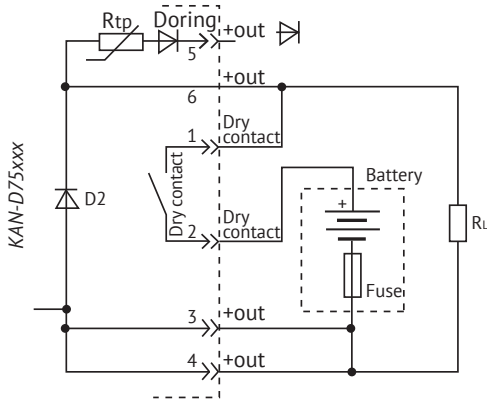

Spark arrestor clamper diagram

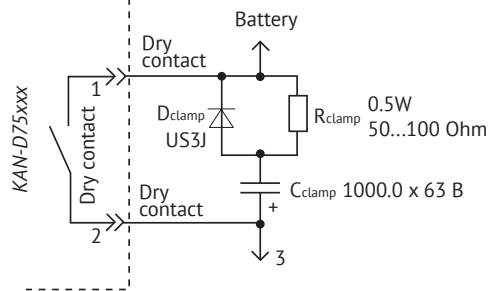

Battery connection diagram with charge current limitation

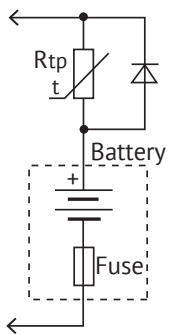

Derating

Input voltage dependency

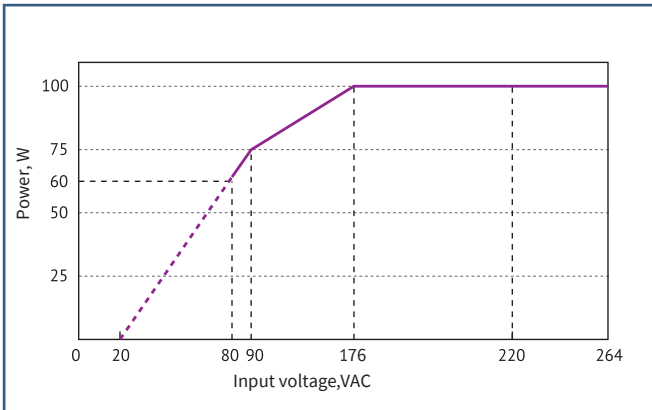

This section discusses the power dependence on input voltage under normal climatic conditions. The dotted line represents the range of input voltages within which the module remains functional with the specified derating, but startup to load is not guaranteed.

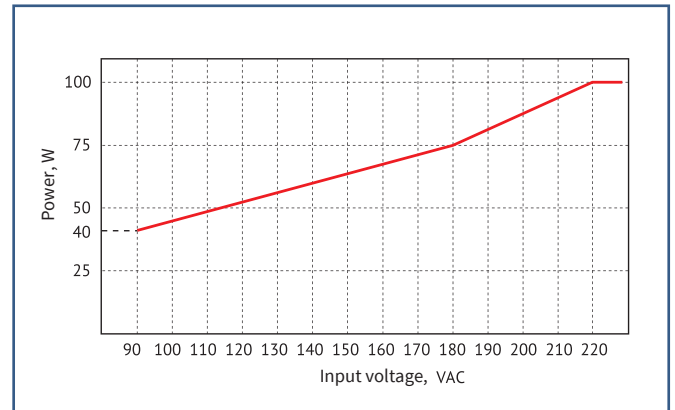

Power dependence on input voltage at tmin for version "P"

Temperature dependence

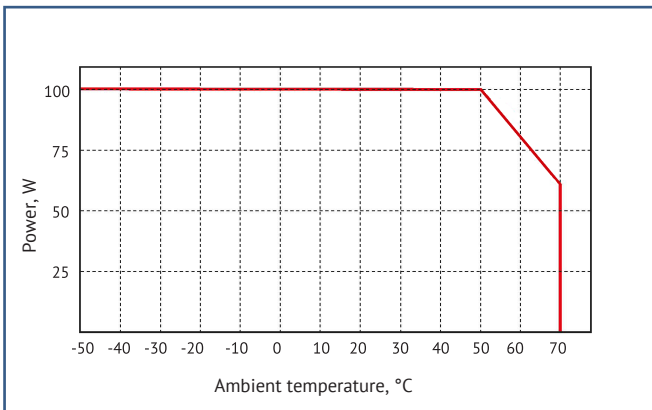

The graph is shown at -50° for the "P" version respectively

Dimensions drawing

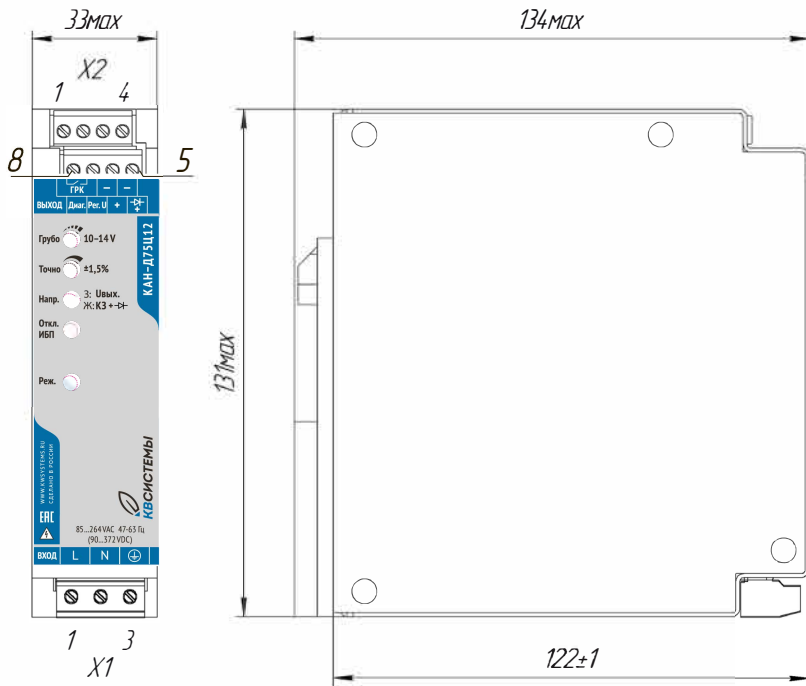

Bracket dimensional drawing Bracket ANZHE.745422.002¹

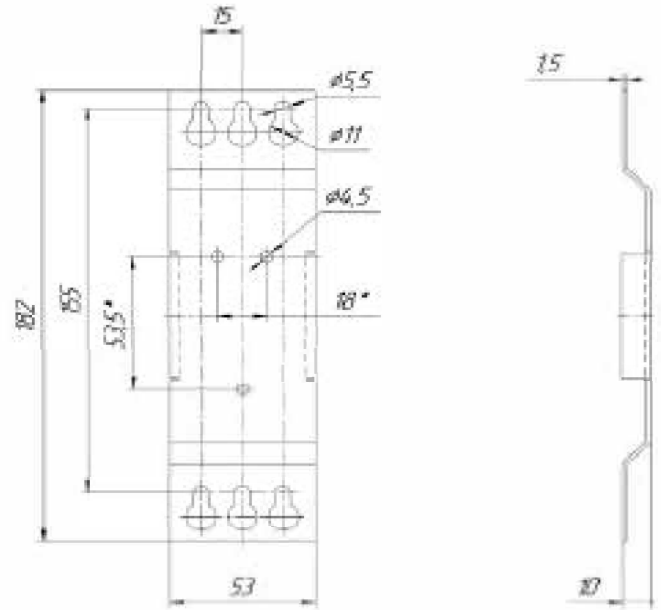

X1			X2							
1	2	3	1	2	3	4	5	6	7	8
L	N	\oplus	DC_OK	DC_OK	-OUT	-OUT	+OUT ORing	+OUT	ADJ.U	DIAG

LED status

LED status	Colour	Operation mode
«Volt» (Voltage)	green	At \pm output pins the voltage is within the nominal range
	yellow	At \pm output pins the voltage is within the nominal range; overload or short circuit at +Oring
	off	No mains / fuse triggering / converter malfunction
«mode»	green	Mains voltage availability and normal operation of the pulse converter
	off	No mains / fuse triggering / converter malfunction

This datasheet is valid for: KAN-D75C12X, KAN-D75C24X, KAN-D75C48X

¹ To be ordered separately