

Application notes

KWadr series **KWadr5000T**

- KWadr5000T30
- KWadr5000T60
- KWadr5000T110
- KWadr5000T140
- KWadr5000T250
- KWadr5000T300
- KWadr5000T350



Table of contents

1. [Introduction](#)
- 1.1. Part numbering
- 1.2. External view and design
2. [Connection and operation](#)
- 2.1. Installation
- 2.2. Input range
- 2.3. Purpose of the front panel indicators
- 2.4. PSU structure
- 2.5. Typical connection
3. [Service functions:](#)
- 3.1. PARAL: output terminal for parallel operation
- 3.2. CAN_H/L bus
- 3.3. CTRL terminal disconnection diagnostics
- 3.4. VS+ VS- voltage sense output terminals
- 3.5. POWER OFF input
- 3.6. Dry contact
- 3.7. Setting unit address, ADR and K_ADR terminals
4. [Parallel operation](#)
- 4.1. Setting unit's address
- 4.2. Parallel operation as part of KAP platform
5. [Serial connection](#)
6. [Current and voltage stabilization modes](#)
7. [Standard faults and trouble shooting](#)
8. [Temperature range, operation in boundary areas](#)

1. Introduction

Universal AC/DC converters of KWadr5000T series are designed both for integration into high power platforms, and for discrete application in telecommunication and radar equipment, machine-building, power industry, security, laser equipment, etc. This product is featured by output voltage up to 350 VDC with wide range adjustment, high efficiency (up to 95%), MIL-STD-461 EMC compliance, adaptive cooling at ambient temperatures -20 to +50°C. Built-in digital control with RS-485 communication interface allows you to combine up to 32 units for a variety of tasks thanks to wide range of adjustments and service functions.

These application notes provide advanced data on connection, operation and performance features. For correct use of PSUs of KWadr5000T series it is advised to read carefully through these application notes.

KWadr5000T series features:

- wide operating temperature range up to -40...+50°C;
- digital control;
- efficiency up to 95%;
- output current or voltage stabilization mode, controlled by software;
- digital adjustment of output current or voltage;
- adaptive cooling;
- parallel operation;
- 19' rack mounting, 1.5 U height;
- dimensions 140x475x63.

1.1. Part numbering

KWadr 5000 T XXX

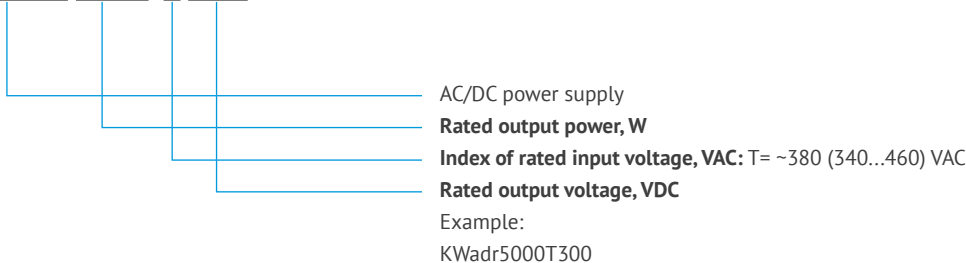

1.2. External view and design

KWadr5000TXXX is fitted into metal case, optionally with fixing flanges.

The units can operate in any position. Units are repairable.

Adaptive cooling by built-in fans with automatic variable speed. The speed is selected by the built-in microcontroller depending on the load and ambient temperature. This increases the service life of fans and reduces noise emission at low power and idle mode. Air is taken from the front panel and being heated is released to the rear.



Fig.1.

To ensure proper cooling, it is recommended to place the components around the unit in such a way as to allow air circulation, intake of cold air and removal of heated air. It is not allowed to place the structural elements to close the grids on the front and rear walls of the unit. Cooling approaches are described in section 8.

2. Connection and operation

2.1. Installation

KWadr5000TXXX is designed for:

- discrete use;
- parallel connection, serial connection;
- use as part of the KAP platform based on KWasar15.

KWadr5000T unit connects to power, load and control circuits through terminal blocks and signal connector located on the rear panel.

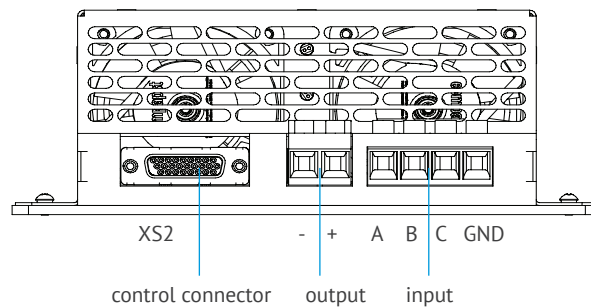

Fig.2.1.

There are two ways to attach unit to the baseplate: through the bottom the unit or through optional mounting flanges. Use M3 screws to mount the unit through the bottom with max 6 mm screw-in depth into the unit's body. Use M6 screws to mount the unit through mounting flanges.

KWadr5000T unit has a height of 1.5U can be mounted in a 19" rack on mounting shelves, up to 3 units on one shelf.

2.2. Input voltage range

KWadr5000TXXX is powered by a three-phase 380VAC 50Hz mains without neutral. Feeding of power supply from three-phase AC mains with neutral is possible, while the neutral is not necessary to connect to the unit. It is safe for the unit and the mains. It is also possible to use DC at the input without derating of output parameters.

KWadr5000TXXX is equipped with built-in active three-phase power factor corrector providing power consumption with factor ≥ 0.95 at full load.

Nominal input voltage index	T
Nominal input voltage, VAC	380
Nominal input voltage frequency, Hz	50; 60*
Established range, V	~ 340 ... ~ 460 VAC = 470... = 640 VDC

⚠ When powered by DC the voltage can be supplied to any of the input terminals «A» and «B-C» free polarity.

2.3. Function of the front panel indicators

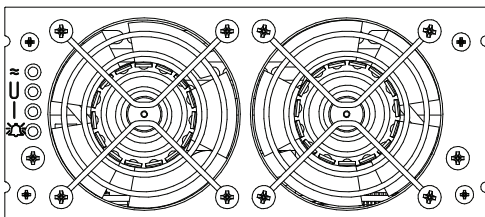

Symbol	LED	Meaning	Permanent	Blinking	PSU condition
≈	green	MAINS	•		mains voltage within rated range (340-460 VAC)
U	green	Ustab.	•		output voltage stabilization
				•	power-off command received
I	green	Istab.	•		output current stabilization / overload
				•	power-off command received
🔔	red	red	•		failure, mains is out of operating range, overheating, overvoltage + accident
				•	fan failure

2.4. KWadr5000TXXX design

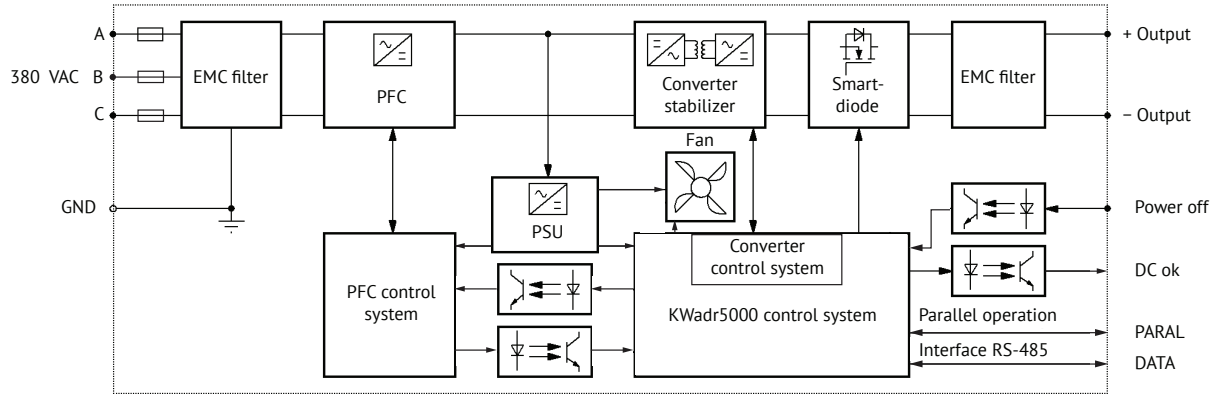

Fig.2.2. KWadr5000TXXX structural diagram

KWadr5000TXXX units contain input EMC filter and protection circuits against excess of input current and voltage.

Output circuits contain a built-in LC filter to ensure the given level of output ripple across the complete operating temperature range, max. 2%. More accurate ripple values are indicated in the Datasheet.

2.5. Typical connection

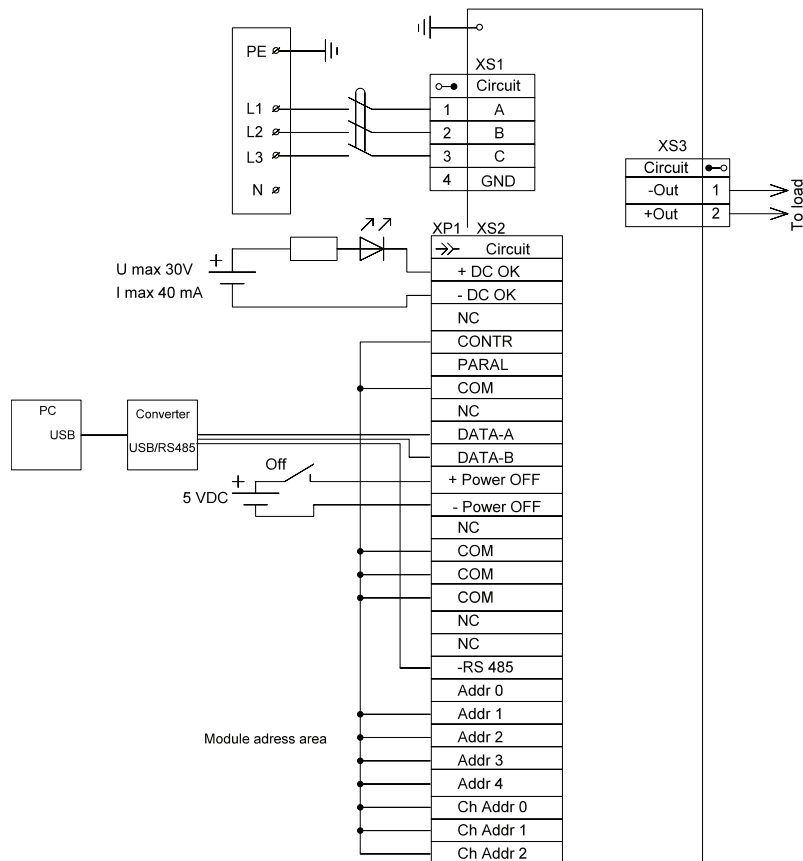

Fig. 2.3. Typical connection of KWadr5000TXXX

After connecting of the mains unit will test its performance, which is indicated by alternate switching of the front panel LEDs. If no errors are detected, the unit will start and operate according to the software presets. It takes 2 to 5 seconds for the unit for self-diagnostics.

✔ **Note that to start the unit, you must connect the CTRL output terminal to the common wire.**

Output voltage can be decreased to lower value using program settings.

⚠ **After disconnecting the working unit from the mains, the unit stops operating. At the same time, the cooling fans go to maximum speed and continue rotating for a few seconds. This is caused by discharge of capacitors to the fans. This is a normal behavior.**

2.6. Remote load

If you have long lines over 50 cm between PSU output pins and terminals or powered functional units, use ceramic capacitors of appropriate voltage in the path of communication lines according to figure 2.4.

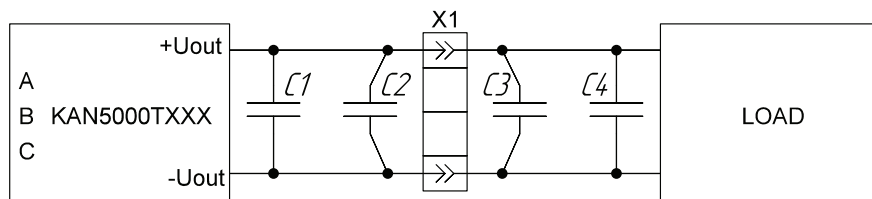

Figure 2.4. Diagram of load connection to PSU with long communication lines

3. Service functions

KWadr5000T contains a connector XS2 for connecting of control and service signals.

3.1. PARAL – output terminal of parallel operation bus. This terminal is necessary for operation of active current equalization system between units operating in parallel, similar to Active Current Sharing function.

3.2. CAN_H и CAN_L – are designed to connect CAN bus required for parallel operation in units KWadr5000X60 and KWadr5000X30. See see ch.4 for detailed description of parallel operation.

3.3. CTRL – output pin for terminal power-off diagnostic. To put the unit to the active mode, the output must be closed to the common wire COMMON. If CTRL output terminal is not connected, the unit is in standby mode.

3.4. VS+ VS- – are remote voltage sense output terminals. To compensate the voltage drop along the load feeding wires, it is recommended to use remote voltage sense function (VS). VS (Remote Voltage Sense) is used in KWadr5000T30 and KWadr5000T60 units. It is an input of remote sense circuits used to stabilize the output voltage at the load. This input is designed to compensate the voltage drop along the load feeding wires and stabilize the voltage directly at the remote load. To use VS function VS terminals must be directly connected to the load by additional wires. In this case the voltage feedback circuit in the unit will automatically maintain a stable voltage at the remote load, compensating for voltage losses in its conducting wires. With RS engaged the output voltage of the unit will be changed dynamically. Voltage drop compensation can reach up to 5%...10%. RS function is useful for the following cases:

- the load is sufficiently remote from the PSU and there is no way to reduce this distance. The resulting voltage drop in conducting wires reduces the voltage at the load, increases ripple and impairs the EMC.

⚠ **For correct operation of the remote voltage sense function, the wires connecting VS terminals to the load must be screened or curled relative to each other. Otherwise, interference to the VS wires may cause uncontrolled changes of the output voltage.**

⚠ **VS + VS- output terminals of remote voltage sense are available only in KWadr5000T30 and T60.**

3.5. Remote OFF/ON

Remote OFF/ON function allows you to turn off the unit by supplying voltage of 5 VDC (3,8...9) VDC from an independent voltage source to the remote OFF/ON terminals (+OFF, -OFF).

Unit response to supply of voltage OFF terminals is programmable.

By default unit is programmed as follows: after disconnecting the unit waits for the voltage to be removed from OFF terminals, after removing the voltage the unit restores operation.

⚠ The response to the voltage at OFF terminals can be programmed as follows. When the voltage is supplied to the unit:

- the unit powers off and starts only after the next supply of input voltage;
- the unit powers on and operates as long as OFF voltage is present.

Voltage between OFF terminals and the output terminals of the unit is 500 V.

3.6. DRY CONTACT

DRY CONTACT function provides remote monitoring of the unit status. If the supply voltage is normal and there are no internal error signals, +DRY CONTACT terminal closes to -DRY CONTACT terminal. The max. voltage drop on the closed contact group is 0.6VDC, the max. Values are 30VDC 40mA, polarity must be observed.

Withstand voltage between OFF terminals and the output terminals of the unit is 500 V.

Setting unit address (ADR and K_ADR terminals) Used for parallel operation of units. See section «Parallel operation» for detailed description.

4. Parallel operation

✓ KWadr5000TXXX units are designed for parallel operation. Follow these conditions for parallel operation:

- connect the units to a three-phase 380VAC 50Hz power supply;
- connect output terminals of the units in parallel, observe polarity;
- set the binary unit number on the XS2 connector;
- connect CTRL terminal to the common wire;
- connect PARAL terminals for active current sharing between parallel operating modules. Connection must be made by shielded conductors, the screen must be connected to COMMON terminal. It should be pointed that PARAL lead exists only at power supplies with 110-350VDC out. For low-voltage 30-60VDC output modules CAN bus operates instead of the parallel lead. To activate parallel operation leads CAN_L and CAN_H should be connected in parallel at all parallel connected modules.
- to control voltage of units connect RS-485 buses.

⚠ The max number of units connected through RS-485 bus is 32 pcs.

KWadr5000TXXX units are connected for parallel operation in accordance with figure 4.1.

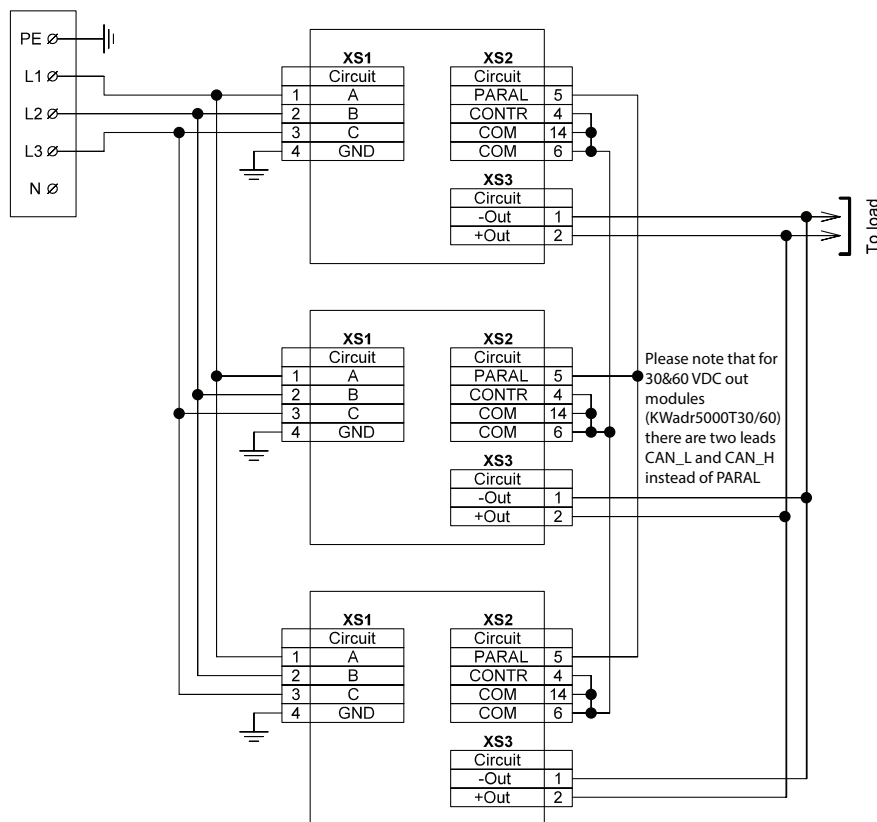

Fig. 4.1. Parallel connection of KWadr5000

Follow these guidelines:

- PSUs must be placed in close proximity to each other;
- wires connecting the output terminals of PSUs to busbars must be the same, of min length and large diameter. In this case the special attention

should be paid to the «minus» of PSUs. Connecting to «minus» output circuits of ORing diodes and current-measuring resistors is not allowed. The busbars must be located in close proximity to the output terminals of the unit and have a cross-section of N times larger than wires connecting the units to the busbar, where N is the number of units connected in parallel.

Connection of the busbars to the load must be located in the middle part of the busbars.

- shield or curl PARAL pins relative to each other, positioning them in such a way as to eliminate interference;
- it is strictly forbidden to switch the output circuits of the powered on units.

⚠ Only units with the same rated output voltage may be used for parallel operation. For example, units with 350 V and 300 V output voltage cannot be used for parallel operation, even if their output voltages are programmed for the same level.

Power supply units operating in parallel for the same load makes it possible to increase the total output power to the following level:

$$P_{total} = 0.8 * N * P_{max},$$

where 0.8 is the recommended unit load factor;

N - number of units connected in parallel.

*Example: 10 units of KWadr5000 operating in parallel will produce $10 * 5000 * 0.8 = 40$ kW.*

N is the value depends on the number of units operating in parallel. For quantity up to 3 N=1. For quantity less than 6 units, N is 0.9; for N over 6 units, N is 0.8.

⚠ If the power supply units are correctly connected, the deviation of output currents of the units should not exceed 10% from their nominal values at the nominal total output power.

4.1. Setting unit's address

✓ When you use a unit without a KAP platform and parallel operation, the unit number does not matter.

In parallel operation, the unit number must be set. The address is programmed by closing the address lines ADR0 ...ADR4 and K_ADR0...K_ADR2 to the common wire. Logical statuses

«0» - the output pin is closed to the general;

«1» - output pin is not connected (pulled up inside to +3V).

The address is programmed in binary 8-bit form with following representation:

ADR4-ADR3-ADR2-ADR1-ADR0-K_ADR2-K_ADR1-K_ADR0

Examples of pin status depending on the address number are given in the table.

Output pin	K_ADR0	K_ADR1	K_ADR2	K_ADR3	ADR0	ADR1	ADR2	ADR3	ADR4
Address 1	0	0	0	0	0	0	0	0	1
Address 2	0	0	0	0	0	0	0	1	0
Address 5	0	0	0	0	0	0	1	0	1

⚠ In parallel operation, the address of unit running on the Same RS-485 bus must not be repeated.

4.2. Parallel operation as part of KAP platform

✓ KWadr5000T units can operate in parallel with the KAP platform based on KWasar15 solution to increase the total power output over 15 kW.

✓ KWasar15 contains 3 units of KWadr5000 and KIP digital control system with following functions:

- setting and monitoring of output parameters, as well as error diagnostics;
- connectivity to external digital control devices such as PC or other microprocessor control system via Ethernet or RS-485 bus;
- possibility to use additional KWadr5000 units to increase output power with active current sharing between the connected units.

KWasar15 with connected KWadr5000 units is a lower level power supply system. When the KWadr5000 units are connected in parallel to KWasar15 platform, high-power system can be controlled via Ethernet interface. It can be controlled by a PC or by a higher level microprocessor device.

Follow these guidelines for parallel operation of additional KWadr5000 units as part of the KAP platform:

- connect the units to three-phase 380VAC 50Hz power supply mains;
- connect output terminals of the units in parallel, observance the polarity;
- set the binary unit number on the XS2 connector; The numbering sequence between units is arbitrary. The numbers of the units connected to the same KWasar15 platform must not repeat;
- connect CTRL output terminal of the connected units to the common wire;

- connect PARAL terminals for active current sharing between parallel operating units and KWasar15 platform. Connection must be made by screened wires, the screen must be connected to COMMON terminal;
- connect RS-485 bus between the units and the KWasar15 to control the voltage of the units.

Meet all the requirements for parallel operation described above. The largest number of KWadr5000 units connected in parallel with KWasar15 platform is 18.

To build a system based on the KWasar15 and KWadr5000 in a 19" rack, the units should be mounted on shelves. The width of one shelf can accommodate up to 3 units of KWadr5000 with a shelf depth of at least 600 mm., Fig.4.2.

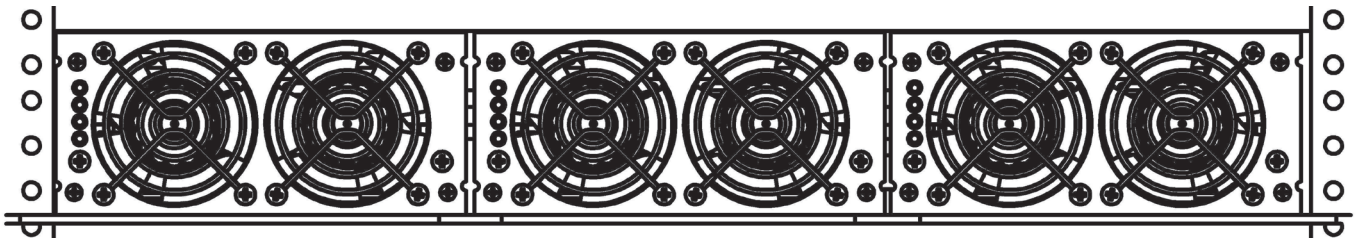

Fig.4.2 Mounting KWadr5000 units on the mounting shelf

Follow the recommendations for parallel connection of KWadr5000 units for connection of input and output power and signal wires.

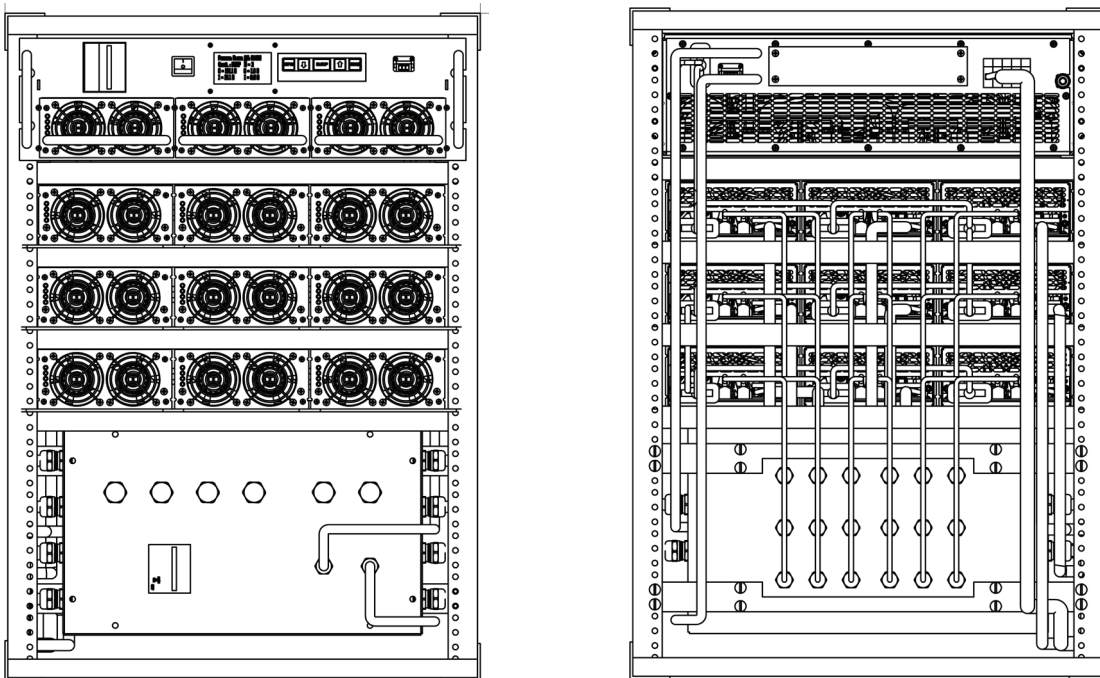

Fig.4.3 Parallel operation of KWadr5000TXXX based on KWasar15: 9 additional units, total power 48 kW.

The power of the shown system of 12*5000T is equal to $12 \cdot 5 \cdot 0.8 = 48$ kW.

An additional unit located at the bottom is used for switching of input and output power circuits. This design is ensured by connection of the unit output terminals by wires of equal lengths, which is necessary for normal parallel operation.

5. Series connection

- ✓ KWadr5000TXXX units can operate with output terminals serially connected to obtain voltage greater than the nominal output.
- ⚠ When connecting the units in series, the voltage between the RS485 interface circuits and negative output conductor must not exceed 500 VDC.

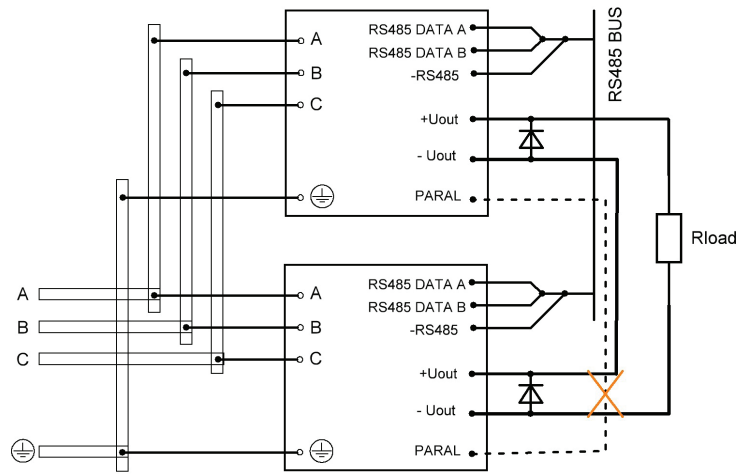

Fig. 5.1. KWadr5000T series connection

6. Current and voltage stabilization modes

✓ KWadr5000TXXX can operate in current or voltage stabilization modes. Thus it is possible to program the vertical and horizontal characteristics of the output voltage. The modes are switched by program.

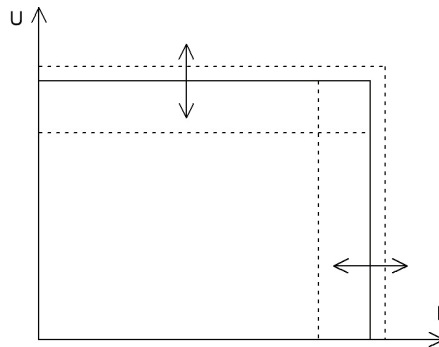

Fig. 6.1.

Buttons TURN ON, U; TURN ON, I; TURN ON, U-I buttons correspond to turning on and/or switching to the corresponding stabilization mode: U-I STABILIZATION, U STABILIZATION, I STABILIZATION.

⚠ In U-I stabilization mode (main and default mode), simultaneous setting (change) of output voltage and current is available.

In U stabilization mode only voltage setting can be changed. Setting of the output current means the maximum current:

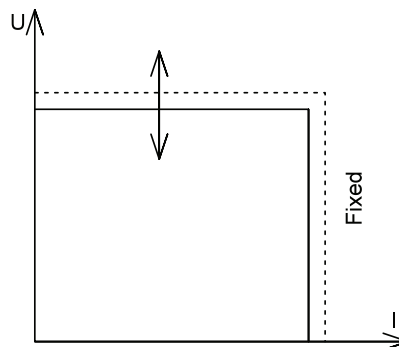

Fig. 6.2.

In I stabilization mode only output current setting can be changed. Setting of the output voltage means the maximum voltage.

In general applications U-I STABILIZATION is the main mode of operation. U STABILIZATION and I STABILIZATION are introduced as auxiliary modes for compatibility with various external control algorithms.

7. Standard faults and trouble shooting

Fault	Cause	Troubleshooting
Output voltage is missing	<ol style="list-style-type: none"> The input voltage is outside operating range. <ol style="list-style-type: none"> One of the phases is missing. There is off-voltage on Remote on/off terminal pins. CTRL output pin is disconnected from the common wire at XS2. Short circuit at the output. Disabled by program. Switched to software-start mode. Unit overheating. The output current is set to a low value that does not correspond to the load. 	<ol style="list-style-type: none"> Apply the input voltage within the specified range. Remove off-voltage from Remote on/off pins. Check program settings of the unit response to Remote on/off pins. Connect CTRL pin to the common wire. Remove the short circuit at the output. 6. Check the program settings. Make the operating temperature lower. Check the program settings, restart the module.
Output voltage is below the nominal level	<ol style="list-style-type: none"> Output overloaded of the unit, overload has not reached the level of short circuit protection. Software restriction. 	<ol style="list-style-type: none"> Reduce the load to the nominal level. Check the program settings.
Output voltage is above the nominal level	<ol style="list-style-type: none"> Program restriction. The feedback terminals « VS » are connected to the load. (in a low-voltage module). 	<ol style="list-style-type: none"> Check the program settings. Check the load voltage.
Output voltage ripple is above the stated value.	<ol style="list-style-type: none"> The module starts at a temperature below -20°C. The load has a pronounced impulse character. 	<ol style="list-style-type: none"> Heat up the unit to the minimum recommended temperature. Install additional containers at the output of the module.
The module is not recognized The PC is either not controlled by RS-485	<ol style="list-style-type: none"> The USB-RS485 adapter is faulty. Incorrect connection to the XS2 connector, communication is broken. Incorrect program settings. 	<ol style="list-style-type: none"> Replace the USB-RS485 adapter. Check the connection to the XS2 connector. Check the program settings.

8. Temperature range, operation in boundary areas

KWadr5000TXXX operating temperature range is from -20°C to +80°C with derating. -20°C to +50°C without derating, continuous.

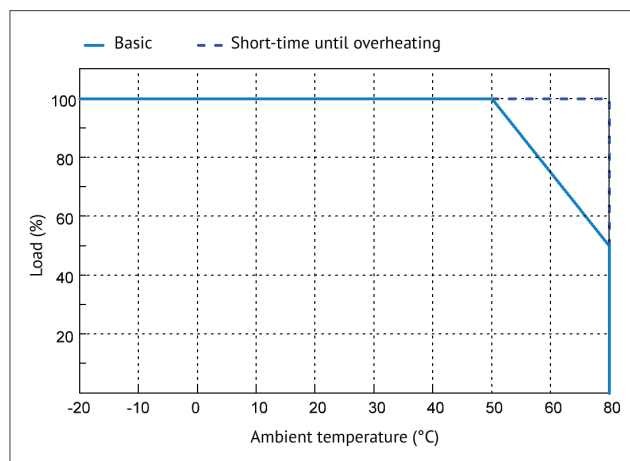

The min temperature is limited by operation of components and fans, lower temperature can be customized to -40°C by the customer request.

The max temperature is limited for internal radiators temperature to not exceed 100°C. When this temperature is reached, the unit turns to the current limit mode to maintain the temperature and continues operating but not switches off.

⚠ Thanks to this feature, the unit can short-time withstand the max power at the max temperature of 80°C without derating, as evidenced by the dotted line. This time is about 2 minutes.

⚠ If there is not enough air circulation inside the unit, output power will also decrease caused by thermal limitation of the output current. During installation consider free space in the front and rear of the unit for air circulation necessary for cooling of the unit.

⚠ During long-term operation in dusty conditions, the temperature curve deteriorates.



www.eng.kwsystems.ru

export@kwsystems.ru

KW Systems, LLC is the leading Russian developer and manufacturer of AC/DC converters and power supply systems for mission critical applications.

Druzinnikov str. 5b, Voronezh, 394026, Russia. +7 473 212 11 58

Customer support service:

Yuri Kazaryan, +7 920 223 04 16 (WhatsApp), techsupport@kwsystems.ru