

AC/DC power supplies

KWant Family

KWant30 NEW, 30 W



Basic specifications

Power	30 W
Output current	up to 6 A
Input voltage	220 (100...264) VAC
Output voltage	5 VDC, 24 VDC, 28 VDC
Efficiency.....	91 % typ.
Case operating temperature.....	-40...+85 °C; -50...+85 °C
Dimensions	101×51×20 mm
Warranty	2 years

Advantages

- ◀ MIL-STD-461E without external components
- ◀ MIL-STD-810G
- ◀ Extra low ripple-and-noise level of 20 mV (at Uout=28 VDC) without external components
- ◀ Convection cooling (without heatsink up to +40°C ambient)



Description of KWant30 on the manufacturer's website:
eng.kwsystems.ru/catalog/acdc/models/1

Order registration

+7 473 200 87 80, Global Operations Team

Technical support

Yuri Kazaryan, techsupport@kwsystems.ru

Ordering information

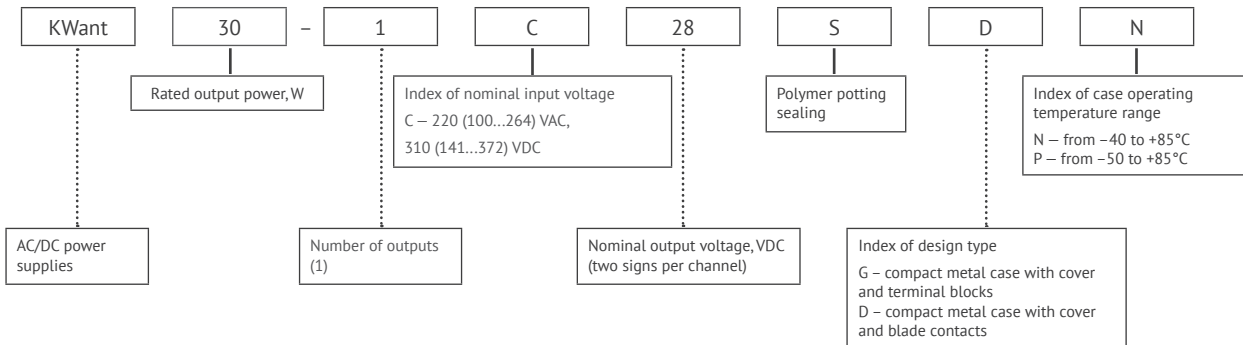

Input specifications*

Parameter	Value
Input voltage range, VAC**	100...264 (141...372 VDC)
Transient deviation range, VAC	100...264
Transient time	1 s.
Mains frequency range, Hz	47...440
I ² t (Joule integral) for pulse-type current	25
Pre-fuse	Slow blow 1,25 A

Output specifications*

Parameter	Value			
Nominal output voltage, VDC	5	12	24	28
Efficiency, %	87	89	91	91
Rated output current, A	6	2.5	1.25	1.1
Ripple and noise (peak-to-peak), mV	< 60		< 50	
Line and load regulation	max 1%		max 0.5%	
Start-up time, ms	<500			
Maximum load capacity	18000 uF	2000 uF	1000 uF	700 uF

* All specifications are valid for normal climatic conditions (ambient temp. +15...+35°C; relative humidity 45...80%; air pressure 8.6*10⁴...10.6*10⁴ Pa), U_{in}. nom., I_{out}. nom., unless otherwise noted.

Protections

Type of protection	
Short-circuit protection	auto recovery
Overload protection	$P_{max} < 1.8 P_{nom}$
Overvoltage protection level	$< 125\% U_{out nom.}$
Overheat protection	triggers at case temperature $> 100^{\circ}C \pm 3^{\circ}C$

Basic specifications

Parameter	5	12	24	27
Type of connection	screw terminals and blade contacts			
Protection level	IP20			
Case temperature, operating	«N»	-40...+85°C		
	«P»	-50...+85°C		
Ambient temperature, storage	-60...+70°C			
Humidity	95% / +25°C			
Isolation voltage	in /case	1500 VAC		
	in /out	1500 VAC		
	out /case	500 VAC		
Isolation resistance @ 500 VDC	$\geq 20 M\Omega min$			
Cooling	convective			
Environmental influence standards	design to meet MIL-STD-810G			
Operational altitude	up to 35 000 m / 115 000 ft			
EMC standards	MIL-STD-461E			
Typical MTBF	20 000 hrs		60 000 hrs	
Case material	metal			
Dimensions, mm	101×51×20			
Weight, kg	0.15			
Warranty	2 years			

Terminal specification, input/output	
Cross section of the flexible conductor, mm ² (max)	0.5...1.5
Cross section of AWG conductor, min	28
Cross section of AWG conductor, max	12
Strip length, mm	6

Block diagram for short-circuit debugging

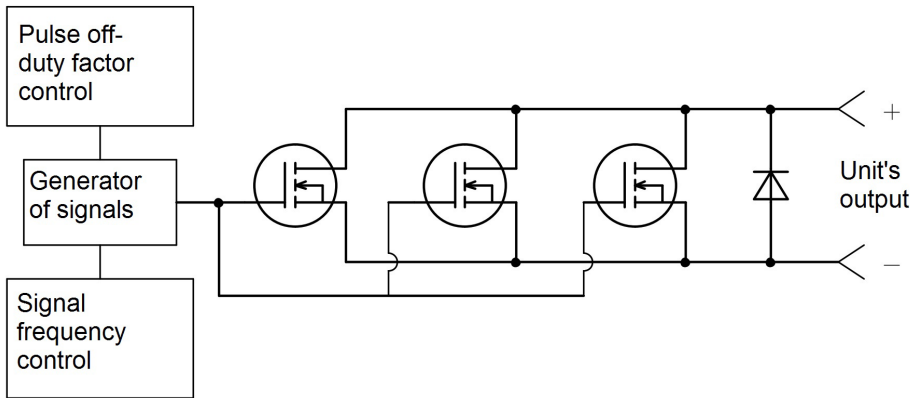

Derating

vs Temperature

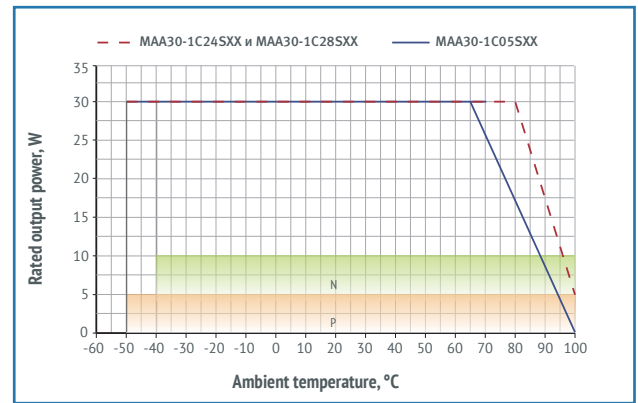
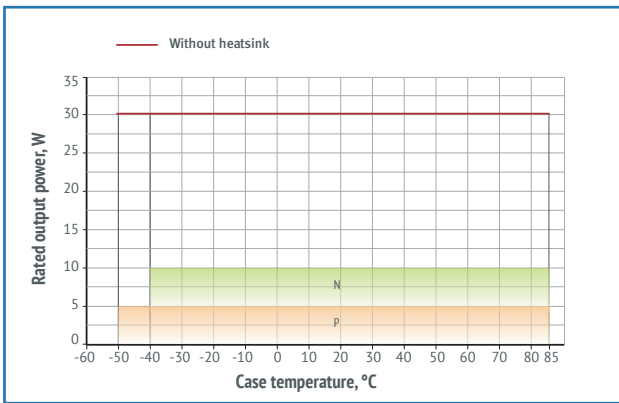

Decreasing parts of the dashed and dash-dotted curves correspond to the maximum case temperature (+85°C for models with index «N» and «P»). Output power must not exceed the values limited by curve for a given ambient temperature.

vs Input Voltage

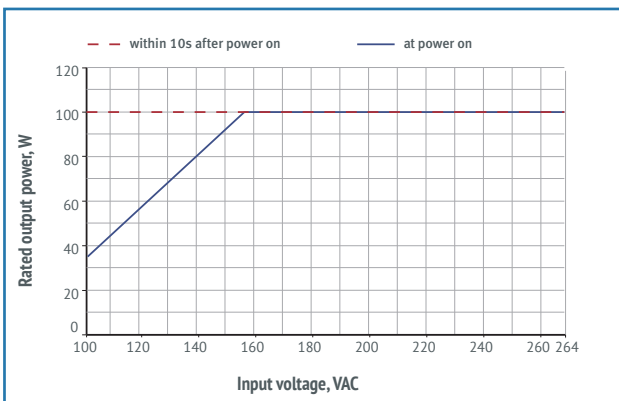

Efficiency

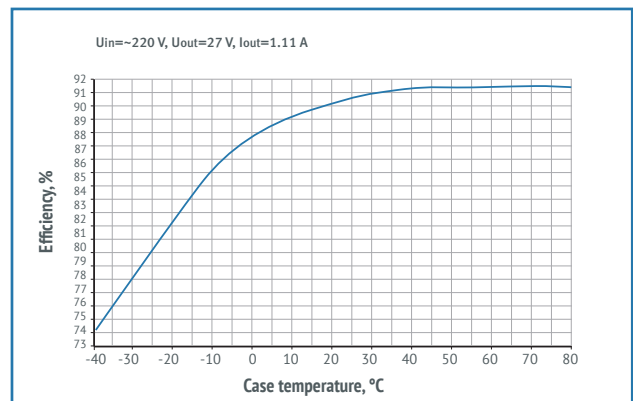

Efficiency

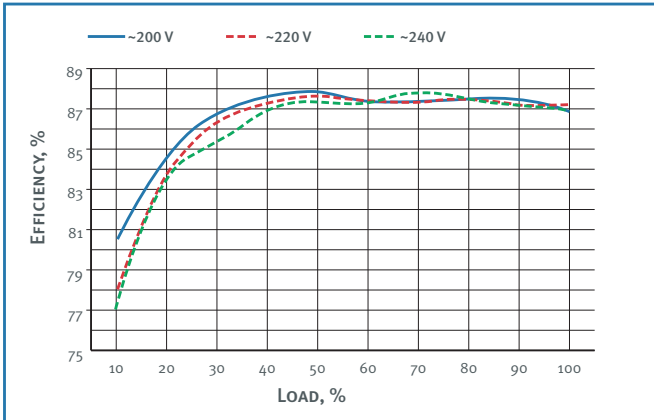

Efficiency vs load for KWant30-1C05SXX

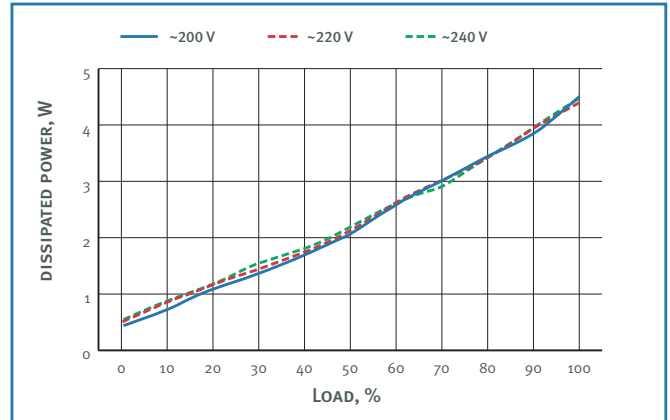

Dissipated power vs load for KWant30-1C05SXX

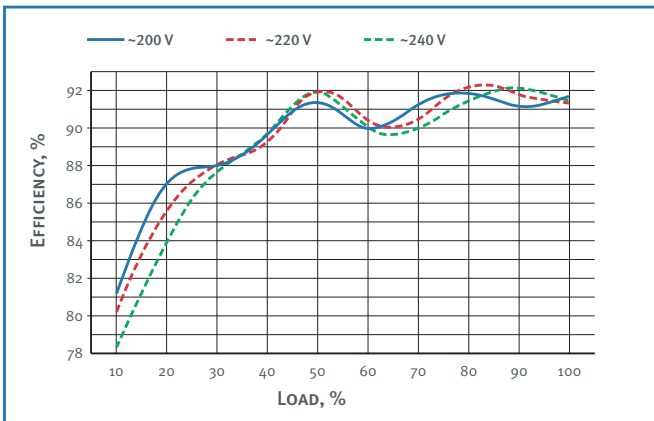

Efficiency vs load for KWant30-1C24SXX and KWant30-1C28SXX.

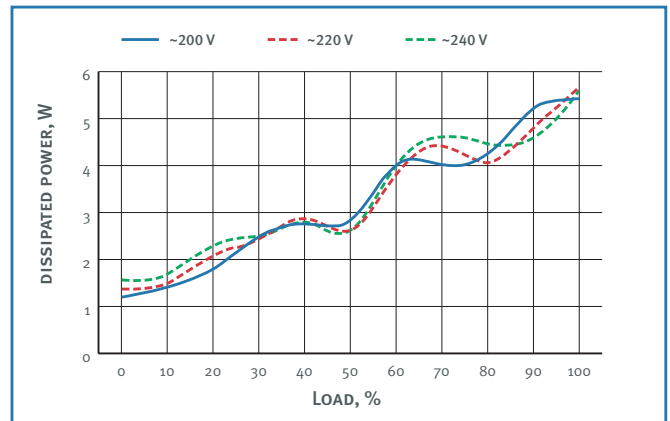

Dissipated power vs load for KWant30-1C24SXX and KWant30-1C28SXX

EMC spectrograms

MAA30-1C05SXX

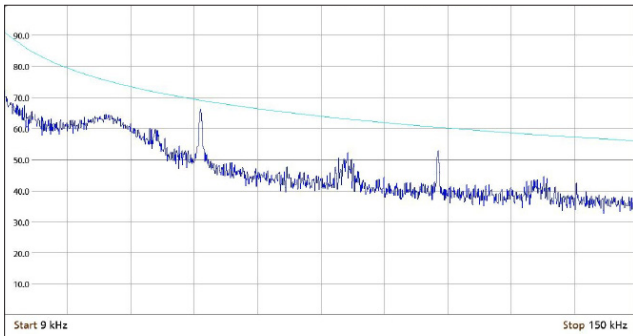

EMI for MAA30-1C05SXX at 9kHz-150kHz within 300Hz step at Max Peak mode.

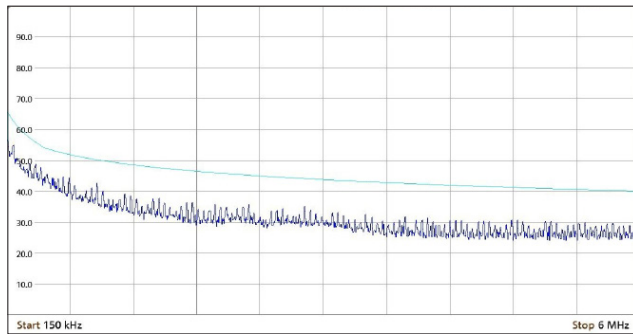

EMI for MAA30-1C05SXX at 150 kHz-6 MHz within 10kHz step at Max Peak mode.

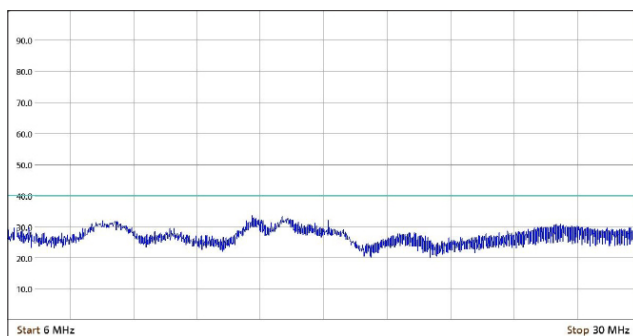

EMI for MAA30-1C05SXX at 6 MHz-30 MHz within 10kHz step at Max Peak mode.

MAA30-1C24SXX, MAA30-1C28SXX

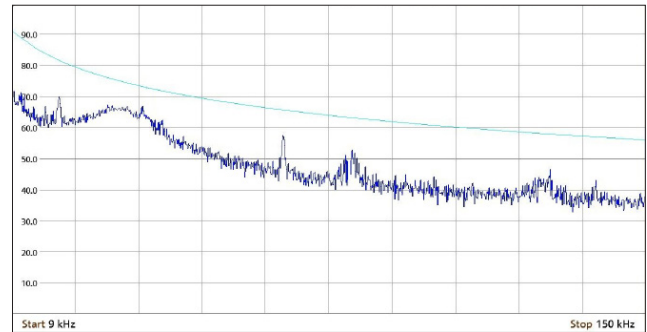

EMI for MAA30-1C2427XX & MAA30-1C28XX at 9 kHz-150 kHz within 300 Hz step at Max Peak mode.

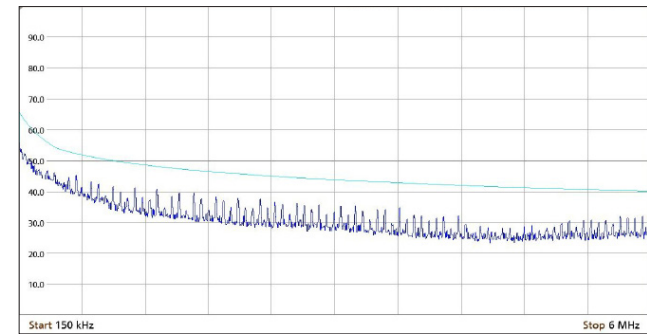

EMI for MAA30-1C24SXX & MAA30-1C28SXX at 150kHz-6 MHz within 10 kHz step at Max Peak mode.

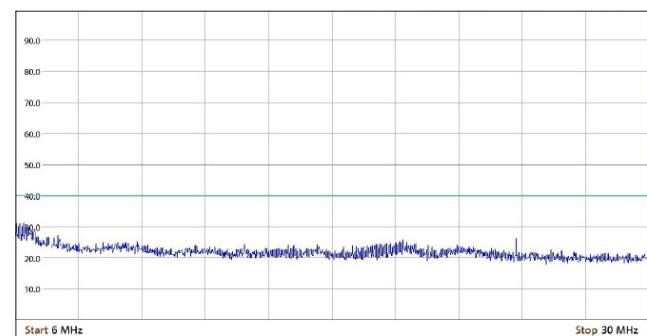

EMI for MAA30-1C24SXX & MAA30-1C28SXX at 6 MHz-30 MHz within 10 kHz step at Max Peak mode.

Oscillograph charts

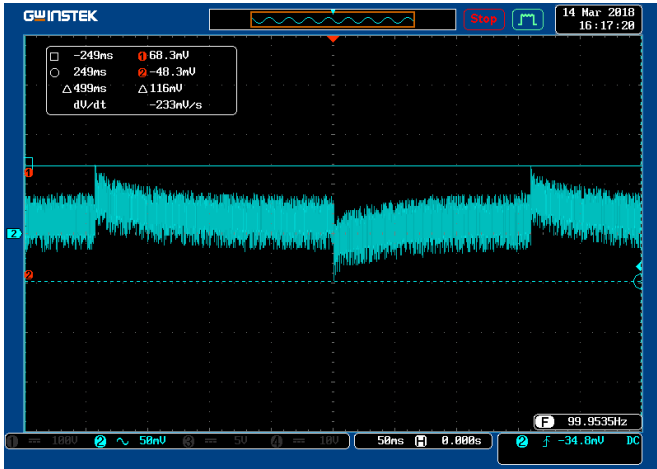

Wavechart of transient deviations of output voltage for KWant30-1C24SXX at dropping and surge of load 50-75-50%. Rate of current rise $di/dt = 2.1$.

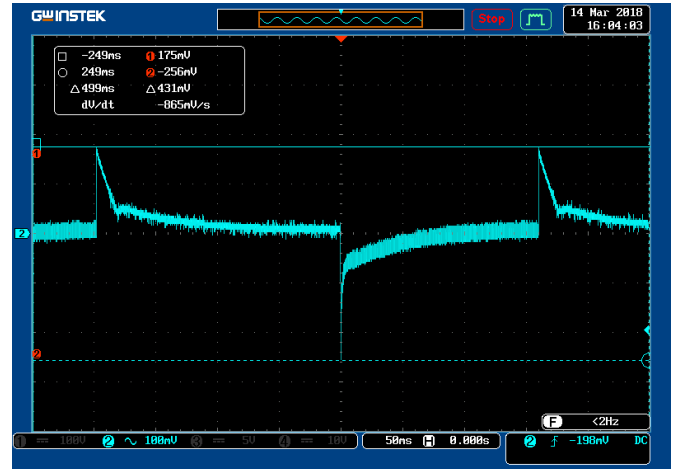

Wavechart of transient deviations of output voltage for KWant30-1C24SXX & KWant30-1C28SXX at dropping and surge of load 0-100-0%. Rate of current rise $di/dt = 2.1$.

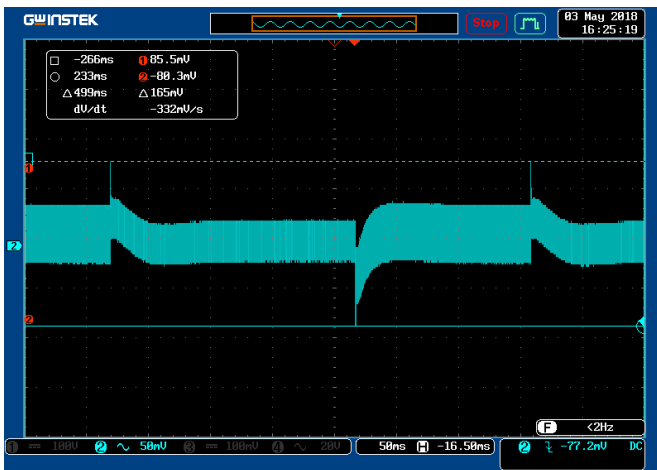

Wavechart of transient deviations of output voltage for KWant30-1C05SXX at dropping and surge of load 50-75-50%.

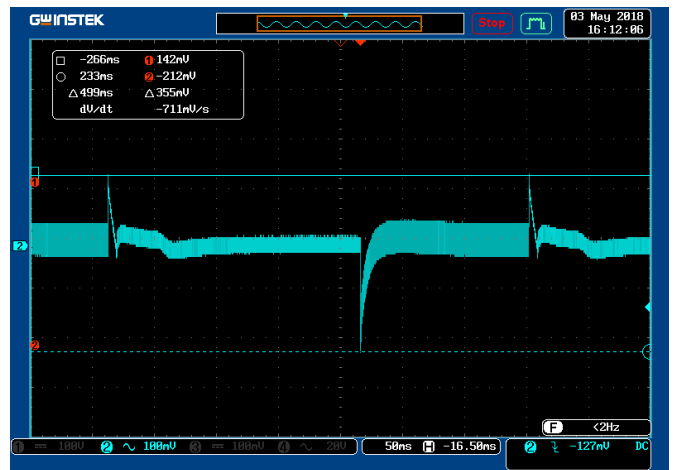

Wavechart of transient deviations of output voltage for KWant30-1C05SXX at dropping and surge of load 0-100-0%.

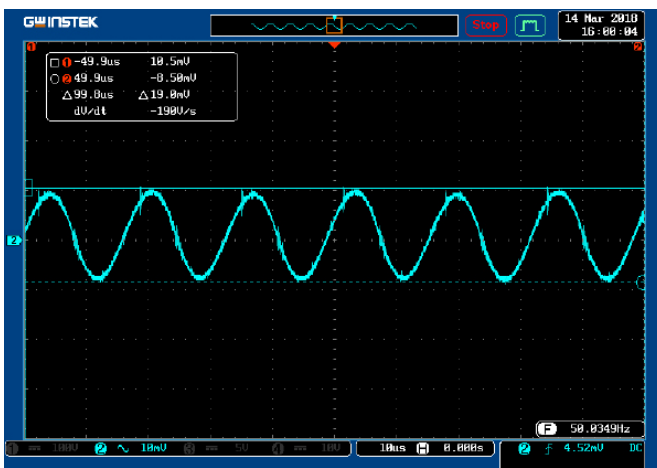

Wavechart of output voltage ripple for KWant30-1C24SXX & KWant30-1C28SXX at bandwidth 20 MHz and 100% load.

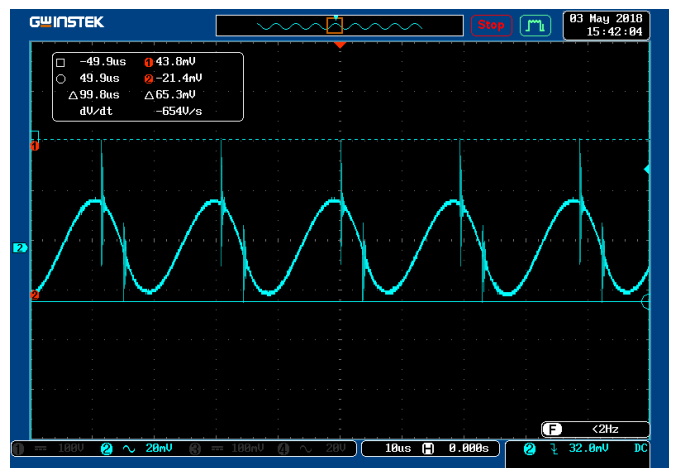

Wavechart of output voltage ripple for KWant30-1C05SXX at bandwidth 20 MHz and 100% load.

Dimensions

Single-channel design with terminal blocks

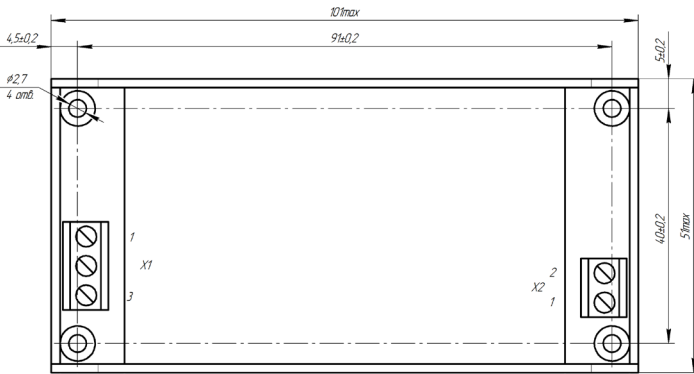

PIN #	X1.1	X1.2	X1.3	X2.1	X2.2
SINGLE-CHANNEL	L	N	⊕	+OUT 1	-OUT 1

Single-channel design with blade contacts

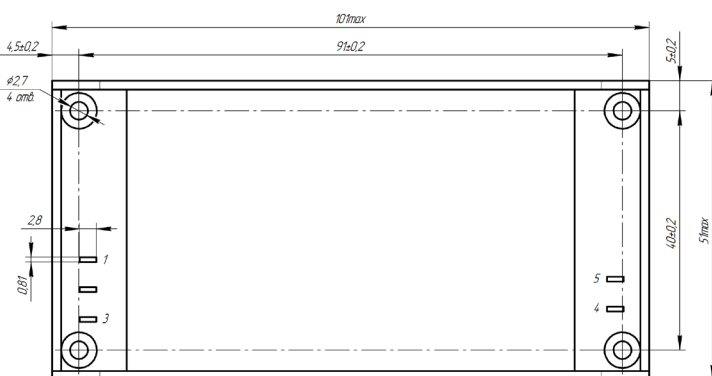
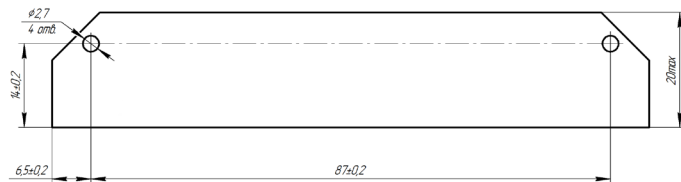

PIN #	1	2	3	4	5
SINGLE-CHANNEL	L	N	⊕	+BblX1	-BblX1



www.kwsystems.ru info@kwsystems.ru

KW Systems, LLC is the leading Russian developer and manufacturer of AC/DC converters and power supply systems for mission critical applications.

Druzinnikov str. 5B, Voronezh, 394026, Russia. +7 473 200-87-80