

HEATSINKS FOR POWER SUPPLY UNITS OF MAA-SERIES

PSU	HEATSINK DECIMAL NUMBER	DIMENSIONS A×B×H×D, mm	C-DIMENSION, mm	FIGURE
MAA30(20)-SXX (SBX, SBX,SKX, SUX)	BKYQ.752695.002	107×56×46×5,1	—	1
MAA60(50)-SXX (SBX, SBX,SKX, SUX)	BKYQ.752695.003	129×59×46×5,1	—	1
MAA180(150)-SXX (SBX, SBX,SKX, SUX)	BKYQ.752695.004	133×97×46×5,1	—	1
MAA400(300)-SXX (SBX, SBX,SKX, SUX)	BKYQ.752695.005	195×106×46×5,1	—	1
MAA800(600)-SXX (SBX, SBX,SKX, SUX)	BKYQ.752695.006	238×122×46×5,1	—	1
	BKYQ.752695.066	238×122×46×5,1	—	2
MAA1200(900)-SXX (SBX, SBX,SKX, SUX)	BKYQ.752695.020	284×172×38×6	—	1
MAA30-SXX (SGX, SDX)	BKYQ.752695.040	97×50×46×5,1	—	1
MAA60-SXX (SGX, SDX)	BKYQ.752695.058	140×75,5×46×5,1	—	1
	BKYQ.752695.058-01	107×5,10×46×5,1	—	2
MAA150-SXX (SGX, SDX)	BKYQ.752695.041	130×83×46×5,1	—	1
	BKYQ.752695.043	260×83×46×5,1	—	1
MAA400-SXX (SGX, SDX)	BKYQ.752695.050	170×92×46×5,1	—	2
	BKYQ.752695.057	170×92×46×5,1	—	1
MAA800-SXX (SGX, SDX)	BKYQ.752695.064	204×116×46×5,1	—	1
MAA1200-SXX (SGX, SDX)	BKYQ.752695.036	284×174×46×5,1	—	2
MAA1500(3000)-SXX (SGX, SDX)	BKYQ.752695.056	249×139×46×11	6	4
MAA400(300)-SXX (SBX, SBX,SKX, SUX)	BKYQ.752695.065	190,5×112×45×10,5	6	3

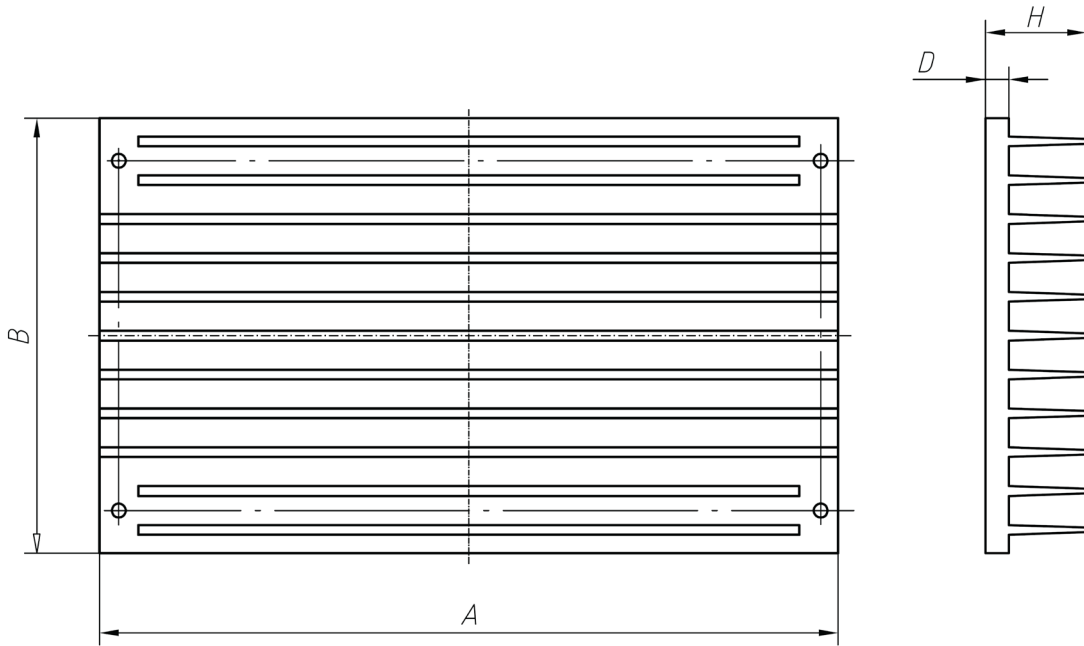

Fig. 1

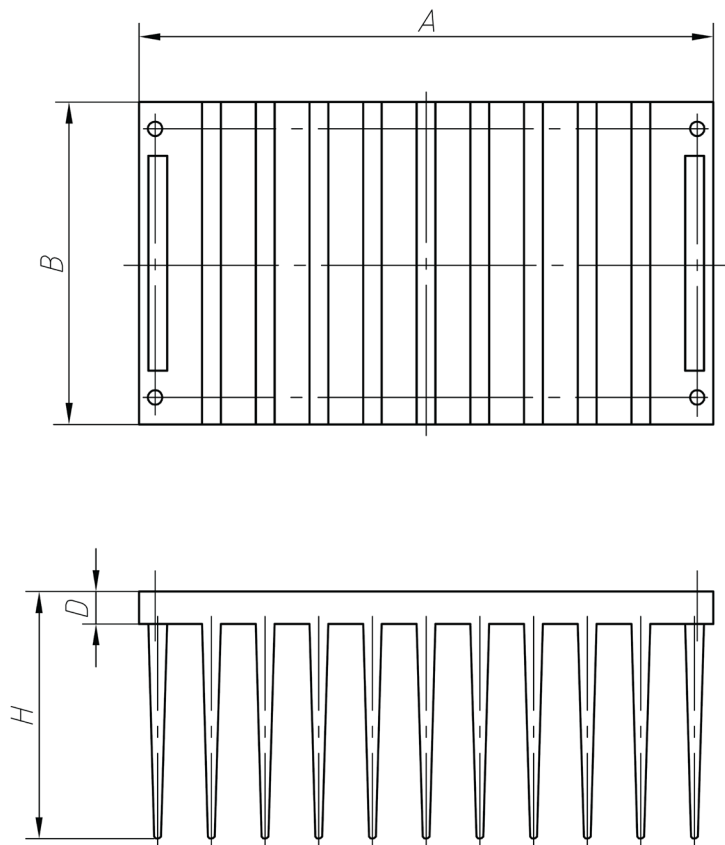

Fig. 2

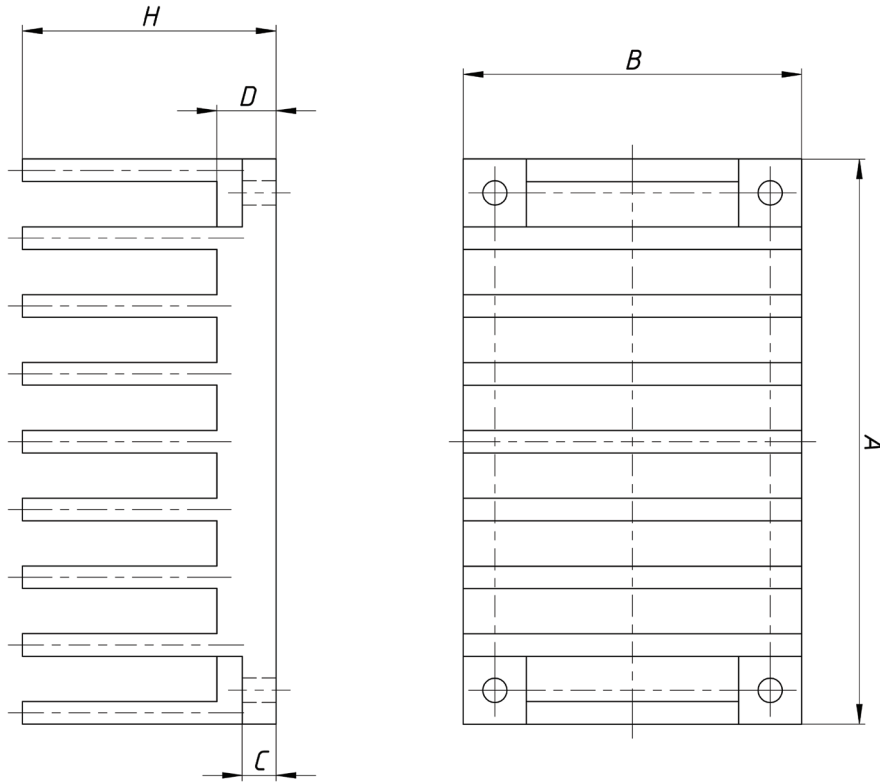

Fig. 3

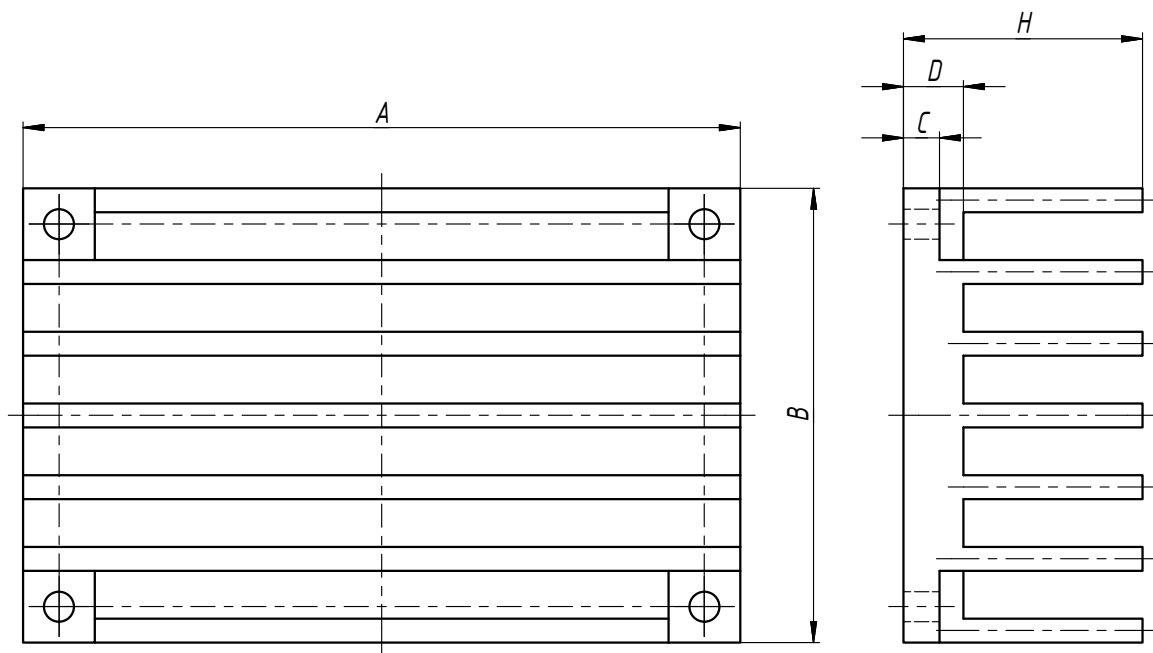

Fig. 4